

Research Article

Development of an Alternative Hybrid Power System using Hybrid Micro Power Optimization Model (HOMER)

Babalola, A. D, Yakubu, A. J.*

Department of Computer Engineering, Federal Polytechnic, Ile-Oluji, Nigeria

Received 20 Jan 2019, Accepted 22 March 2019, Available online 27 March 2019, Vol.7, No.1 (March 2019)

Abstract

Nigeria is endowed with abundant energy resources, both conventional and renewable, which can potentially provide the country with a sufficient capacity to meet the ambitions of both urban and rural Nigerians of a full, nationwide electrification level. Yet, Nigeria has one of the lowest consumption rates of electricity per capita in Africa. With the demand superseding the generation, there is inequitable access of rural communities to the electricity service in the country. There are inherent obstacles militating against the effective implementation of an orderly energy policy in Nigeria. The inefficiencies overshadowing the allocation of energy resources coupled with the near depletion of fossil fuels, make it imperative for the country to exploit its huge natural renewable resources to avoid a worsening energy supply scenario and provide feasible electricity to rural dwellers. This project presents a review of renewable energy potentials in Nigeria to be tapped for useful and uninterrupted electric energy supply. This study provides a detailed analysis of the quantum of electricity supply to Ilesha garage, Akure and how to supplement for lose hours in power supply (i.e. hours lost to power outage) via solar energy to augment for 18 hours of power unavailability in the community.

Keywords: Hybrid Power System, Development, Optimization, Model, Micro Power

Introduction

An optimization is the making the best or most effective use of a situation or resource. It is also the process of finding an alternative with the most cost effective or highest achievable performance under the given constraints, by maximizing desired factors and minimizing undesired ones. Over last several decades demand for electrical energy on a world-wide level is growing rapidly. Energy services are considered as a driving force of economic development, and its sociological benefits cannot be neglected. However, current patterns of energy production are polluting and unsustainable, and are characterized by inequity in consumption and access. The challenge is to improve access of modern energy services, without increasing reliance on fossil fuels. Recent approaches meet this challenge with a focus on application of renewable energy recourses, such as wind, solar and hydro, which are especially suited for decentralized electricity generation [T. Gul, 2004]. However, application of renewable energy resources has two major problems, i.e. instable energy provision due to fluctuating nature of the resources and location dependency; therefore, there are no universal methods when developing

renewable energy power system for a specific site. The research that is presented in this journal is oriented towards application of renewable energy resources (wind and solar) in standalone power systems (SAPS).

Due to absence of respective guidelines, the analysis is performed with methodology that is developed for this research only. The overall objective of this journal is to analyse both energetically and economical aspects of designing the optimal standalone power system for remote area object. A smaller part of this research refers to investment expenses of connecting the remote area object to electrical grid, while the main part concerns the optimal configuration of hybrid standalone power system which uses wind power and solar radiation. The purpose of the paper is to present implications and solutions when designing hybrid photovoltaic/wind power systems. The approach that has been implemented in this study can result with quality solutions, and based on them; decision can be made concerning the feasibility of hybrid power system on a specific location.

Over the last decades, demand for electricity on a world-wide level is growing rapidly. Energy services are considered as a driving force of economic development, and its sociological benefits cannot be neglected. However, current patterns of energy production are polluting and unsustainable, and are

*Corresponding author's ORCID ID:
DOI: <https://doi.org/10.14741/ijaie/v.7.1.1>

characterized by inequity in consumption and access. The challenge is to improve access of modern energy services, without increasing reliance of fossil fuels. Recent approaches meet this challenge with a focus on application of renewable energy resources, such as wind, solar and hydro, which are especially suited for decentralized electricity generation (T.Gul, 2004). However, application of renewable energy resources has two major problems, i.e instable energy provision due to fluctuating nature of the resources and location dependency; therefore, there are no universal methods when developing renewable energy power system for a specific site.

HOMER [www.nrel.gov/homer/] or hybrid micro power optimization model, is a powerful software that simplifies the task of evaluating designs both off-grid and grid-connected power systems for a variety of applications. In order to use HOMER, user must provide model with inputs which describe technology options, component costs, and resource availability. HOMER uses those inputs to simulate different system configurations and generates results that user can view as a list of feasible configurations sorted by net present cost, so user can compare configurations and evaluate them on their economic and technical merits. HOMER also performs sensitivity analysis; if given sensitivity values that describe a range of resource availability and component costs. Results of a sensitivity analysis can identify the factors that have the greatest impact on the design and operation of the power system. The reason that HOMER is used in this research is simple; it combines both economical and electrical aspects of designing hybrid on-grid or off-grid power systems. HOMER energy is the exclusive developer and distributor of the HOMER software, the global standard for optimizing micro grid and distributed energy resource designs in all sectors. HOMER software is having over 150,000 users in more than 190 countries; HOMER is global standard for micro grid and distributed energy system design.

Power is the energy that is produced by mechanical, electrical, or other means and used to operate a device. It is also known as the rate of doing work, measured in watts or less frequently horse power. Energy is the power derived from the utilization of physical or chemical resources, especially to provide light and heat or to work machines. It is best known to be the capacity for doing work, it may exist in potential, kinetic, thermal, electrical, chemical, nuclear, or other various forms. All forms of energy are associated with motion.

A renewable resource is a natural resource with the ability to reproduce through biological or natural processes and replenished with the passage of time they will never run out. This fact shows us that we should exploit renewable sources much more and that we do not have to worry about the energy after fossil fuels cease to exist. Development of renewable energy sources (especially from wind, water and sun) is important because of a couple of reasons: Renewable

energy sources have major role in decreasing emissions of the carbon dioxide (CO₂) into atmosphere. Increased proportion of renewable energy sources enhances energetic viability of the energy system. It also helps to enhance energy delivery security by decreasing dependency on importing energetic raw materials and electrical energy. The solar power industry has seen substantial growth over the past decade. This section of the study is going to explain the four different types of solar power. The current market conditions of the solar industry will then be reported.

Solar power actually referring to four different ways that the sun's power can be harnessed. The most common type of solar power is the photovoltaic cells that convert sun light to electricity. There are also heating and cooling systems that are powered by the sun; they are referred to as solar thermal systems. Concentrated solar power is the third type of solar power; it involves utility scale photovoltaic projects. The last type of solar power is lighting which involves saving electricity by installing skylights or windows based on the sun's position in the sky throughout the year (Solar Energy Industries Association, 2008). Solar energy can also be broken into two types of systems, active and passive. Active solar systems convert the sun's heat and light into another form of energy. Passive solar power comes from special designs or building material that use the sun's position in the sky to provide direct heating or lighting. Passive solar projects also consider the need for shade on the building (Solar Energy Industries Association, 2008). Since the industrial revolution in the late 18th and early 19th centuries, society has become fixated on harvesting our limited resources for the production of industrial and consumer goods. The obvious issue with this reliance is that these resources are finite; therefore, there must be a point in the future in which they run out. With this issue increasing every day as more resources are used, people across the world are looking for a solution that doesn't rely on our finite resources like oil, coal, and even water, turning to "greener" practices like solar and wind energy.

These energy sources will be important as society shifts toward renewable energy to solve many of the environmental issues caused by our historically toxic practices, like coal mining, racking, and nuclear fusion. These renewable energy sources also offer imminent financial benefits, as it becomes cheaper to produce and implement them. Solar has become one of the fastest growing renewable energy sources. It provides an excellent solution to the issue of our diminishing finite resources. Solar also provides energy "security" because it is harvested from our most abundant resources, the sun. For this reason, solar energy will be a viable option for energy as long as the sun exists.

Photovoltaic solar panels absorb sunlight as a source of energy to generate electricity. A photovoltaic (PV) module is a packaged, connected assembly of typically 6x10 photovoltaic solar cells. Photovoltaic

modules constitute the photovoltaic array of a photovoltaic system that generates and supplies solar electricity in commercial and residential applications. An electric battery is a device consisting of one or more electrochemical cells with external connection provided to power electrical devices. When a battery is supplying electric power, its positive terminal is the cathode and its negative terminal is the anode. An inverter is an electronic device or circuitry that changes direct current (DC) to alternating current (AC). The input voltage, output voltage depends on the design of the specific device or circuitry. The inverter does not produce any power; the power is produced by the DC source.

A charge controller, charge regulator or battery regulator limits the rate at which electric current is added to or drawn from electric batteries. It prevents overcharging and may protect against overvoltage, which can reduce battery performance or lifespan, and may pose a safety risk. It may also prevent completely draining a battery, or perform controlled discharges, depending on the battery technology, to protect battery life. An electric cable is an assembly of one or more wires running side by side or bundled, which is used to carry electric current. Energy is what is produced by mechanical, electrical, or other means and used to operate a device. Power is the rate at which electrical energy is converted to another form, such as motion, heat, or an electromagnetic field. The common symbol for power is the uppercase P. the standard unit is the watt symbolized by W. In utility circuits, the kilowatts (kW) is often specified instead; 1kW=1000w.

Literature Review

In 2010, S. Ali Pourmousavi *et al.* have proposed the application of particle swarm optimization (PSO), which is a biologically inspired direct search method, to find real-time optimal energy management solutions for a stand-alone hybrid wind-micro turbine (MT) energy system, was presented. Results demonstrate that the proposed PSO-based energy management algorithm could solve an extensive solution space while incorporating many objectives such as: minimizing the cost of generated electricity, maximizing MT operational efficiency, and reducing environmental emissions. Actual wind and end-use load data were used for simulation studies and the well-established sequential quadratic programming optimization technique was used to validate the results obtained from PSO. Promising simulation results indicate the suitability of PSO for real-time energy management of hybrid energy systems.

Power generation systems (PGSs) based on hybrid renewable energy is one of the promising solutions for future distributed generation systems. Among different configurations, hybrid photovoltaic-wind turbine (PV-WT) grid connected PGSs are the most adopted for their good performance. However, due to the complexity of the system, the optimal balance between these two energy sources requires particular attention

to achieve a good engineering solution. In 2012, Mohammed Alsayed *et al.* have proposed the optimal sizing of PV-WT by adopting different multicriteria decision analysis (MCDA) optimization approaches. Sensitivity of MCDA algorithms has been analyzed, by considering different weighting criteria techniques with different fluctuation scenarios of wind speed and solar radiation profiles, thus highlighting advantages and drawbacks of the proposed optimal sizing approaches. The following study could be assumed as a powerful roadmap for decision makers, analysts, and policy makers. In 2010, E.S. Sreeraj *et al.* have proposed a method to optimally size and to evaluate the cost of energy produced by a renewable hybrid system was proposed, which was based on the design space approach, could be used to determine the conditions for which hybridization of the system was cost effective.

The simple and novel methodology, proposed in that paper, was based on the principles of process integration. It finds the minimum battery capacity when the availability and ratings of various renewable resources as well as load demand were known. The battery sizing methodology was used to determine the sizing curve and thereby the feasible design space for the entire system. Chance constrained programming approach was used to account for the stochastic nature of the renewable energy resources and to arrive at the design space. The optimal system configuration in the entire design space was selected based on the lowest cost of energy, subject to a specified reliability criterion.

The effects of variation of the specified system reliability and the coefficient of correlation between renewable sources on the design space, as well as the optimum configuration were also studied in that paper. The proposed method was demonstrated by designing an isolated power system for an Indian village utilizing wind-solar photovoltaic- battery system. In 2011, Taher Niknam *et al.* have presented a multi-objective optimization algorithm for the siting and sizing of renewable electricity generators. The objectives consist of minimization of costs, emission and losses of distributed system and optimization of voltage profile. This multi objective optimization was solved by the improved honey bee mating optimization (HBMO) algorithm. In the proposed algorithm, an external repository was considered to save non dominated (Pareto) solutions found during the search process. Since the objective functions were not the same, a fuzzy clustering technique was used to control the size of the repository within the limits. This algorithm was executed on a typical 70-bus test system. Results of the case study show the proper siting and sizing of REGs were important to improve the voltage profile, reduce costs, emission and losses of distribution system. The main feature of the algorithm refers to its accuracy and calculation speed. In 2011, A.B. Kanase-Patil *et al.* have proposed the electrification of dense forest areas of Uttarakhand state in India by Integrated Renewable

Energy Optimization Model (IREOM). The IREOM consists of locally available renewable energy resources such as Micro Hydropower (MHP), biomass, biogas, wind and solar photovoltaic (SPV) systems have been used to meet electrical energy and cooking energy needs of a cluster of villages. The proposed paper includes the selection of different system components, sizing and development of a general model to find out optimal combination of energy subsystems for the selected study area in order to minimize the cost of energy (COE) generation for a required reliability values. The sizing of different renewable energy system components has been carried out so that they are suitable for four different seasonal load profiles. The two reliability values were considered for the selection of optimum solution of year round application. The model developed for that purpose, has been found to be quite useful in optimizing the renewable energy system sizes that were available in market. The proposed model totally depends on the renewable energy systems and eliminates the use of conventional energy systems. This literature review will explore previous literature on solar power, wind power, power cells, and the feasibility of renewable energy systems. The solar power section will look at the types of solar power, the current conditions of the solar industry, and how government policies are helping that industry. The wind power section will explain how wind energy is converted to electricity, look at the current industry conditions for wind power production, and explore the feasibility and possible future of wind energy. The power cell portion of the literature review will explain how power cells work and explore their costs and benefits. Lastly, the feasibility of renewable energy systems section will give a brief overview of previous case studies of renewable energy systems in the hospitality industry.

Methodology

In the methodology section of this research, the data input sources will be explored and evaluated. These data was obtained from the Benin Electricity Distribution Plc (BEDC). These data gives the rate at which electricity was consumed daily for the month of February. In this project, we shall make use of secondary analysis to analyse the data. The method and criteria that the HOMER software uses to test the feasibility of different electrical system will also be explained. Lastly, the results of the optimization test run by the software will be examined and explained.

(i) Parameters to be considered

The capacity required for the power voltage in the area and the equipment required for the solar set-up includes: Solar Photovoltaic system, Storage device, Inverters and Charge controller. Other includes cost of the solar equipment, space of land for setting up a solar farm for the area and load required of the solar farm.

(ii) Solar PV Model

By using HOMER software the solar resource input throughout the year is obtained month wise for a particular region is given.

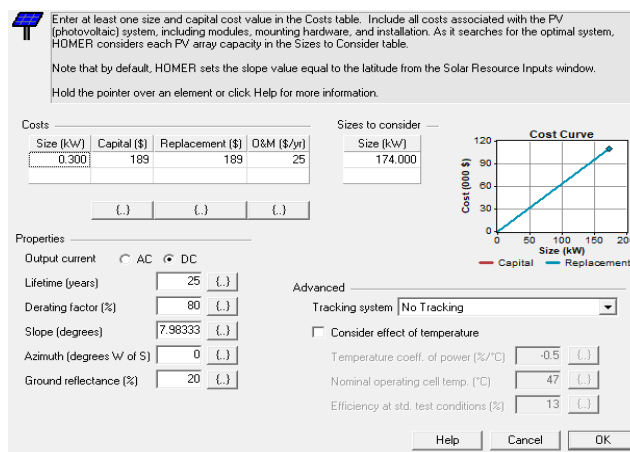

Fig. 3.1: Solar PV model

Storage Device

In order to store the energy from the hybrid system compromises of Solar PV the system is modelled so that the energy can be stored in battery and can be used during low solar radiation or during cloudy days or rainy days. The storage device can also provide the stored power during the night.

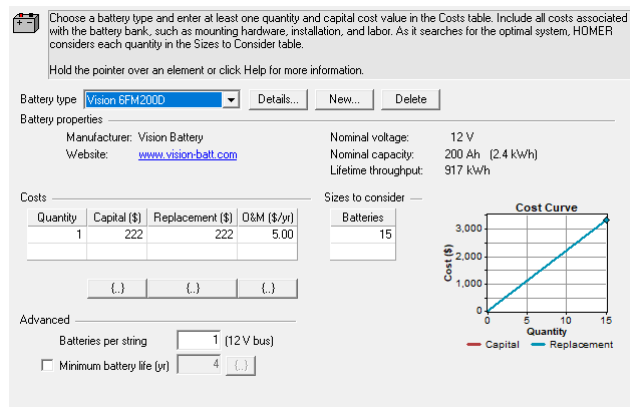

Fig. 3.2: Storage battery

(iv) Charge Controllers

A charge controller, charge regulator or battery regulator limits the rate at which electric current is added to or drawn from electric batteries. It prevent overcharging and may protect against overvoltage, which can reduce battery performance or lifespan, and may pose a safety risk. It may also prevent completely draining a battery, or perform controlled discharges, depending on the battery technology, to protect battery life.

(v) Inverter

An inverter is an electronic device or circuitry that changes direct current (DC) to alternating current (AC). The input voltage, output voltage depends on the design of the specific device or circuitry. The inverter does not produce any power; the power is produced by the DC source.

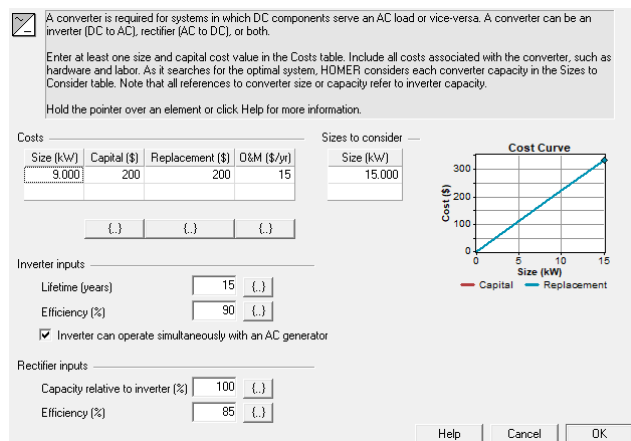

Fig.3.3 Inverter

(vi) Data Inputs

The electricity use data inputs for the HOMER software came from the bimonthly electricity bills in Akure city is received. The average electricity use for each month was then split evenly to form daily electricity consumption. These daily electricity consumption amounts were then split evenly again to form the hourly consumption of the area. The model would have been much more accurate if true hourly electrical data from the city was used instead of estimates, but that information has not been collected. To make this a more accurate study, the result would need to monitor its hourly electricity consumption for an entire month and import that data into the HOMER software.

(vi) Capacity Required for the Power Outage in the Community

According to the daily/hourly data obtained from Benin Electricity Distribution Company (BEDC), an average of 6 hours electricity was supplied daily to the community and 18 hours power outage. The total power load needed in the community is 1000kW, while the total power that will augment for the 18 load shaded hours is 941kW (Table 3.1).

Table 3.1: Average consumption of power for 28 days

Days	Current	Voltage	Power factor
1	2822	220	0.8
2	1368	220	0.8
3	1069	220	0.8
4	1490	220	0.8
5	2061	220	0.8
6	1361	220	0.8

7	1547	220	0.8
8	1483	220	0.8
9	2097	220	0.8
10	358	220	0.8
11	1937	220	0.8
12	2375	220	0.8
13	2983	220	0.8
14	2100	220	0.8
15	1642	220	0.8
16	2205	220	0.8
17	724	220	0.8
18	2047	220	0.8
19	0	220	0.8
20	1804	220	0.8
21	1877	220	0.8
22	1599	220	0.8
23	2093	220	0.8
24	325	220	0.8
25	1965	220	0.8
26	1890	220	0.8
27	2016	220	0.8
28	1645	220	0.8
TOTAL	46883	6160	
AVERAGE	297.391	220	

The average current supplied for 28 days in this community is 297.391kW.

$$P = IVCOS\phi$$

$$P = \text{power}$$

$$I = \text{current}$$

$$V = \text{voltage}$$

$$COS\phi = 0.8 \text{ (power factor)}$$

$$P = IVCOS\phi$$

$$I = 297A$$

$$V = 220V$$

$$COS\phi = 0.8$$

$$P = 297 \times 220 \times 0.8 = 52.272kw.$$

So in this community, 52.272kw is supplied hourly. For 24 hours, 52.272 X 24 hours = 1254.528kw is supplied.

From the data obtained from the Benin Electricity Distribution Company Plc, the utility supplied to this community is majorly six hours daily, and this project is to augment for the power outage daily which is 18 hours. So to achieve this, the power to be generated for the 18 hours goes thus;

$$52.272 \times 18 \text{ hours} = 941kW.$$

$$\text{Tolerance} = 59kW$$

We are to consider tolerance in this system to avoid breakdown of the system, to prolong the lifespan of the equipment and to generate the loads required of the community in excess. So to achieve this, we consider generating;

$$1.13 \times 52.272 = 59KW$$

The real power to be generated is 1000kW.

(vii) The Solar Radiation for the Area

The longitude and latitude of the community is 7.2876 North and 5.1615 East, the solar information of the area for a year is analysed in figure 3.1;

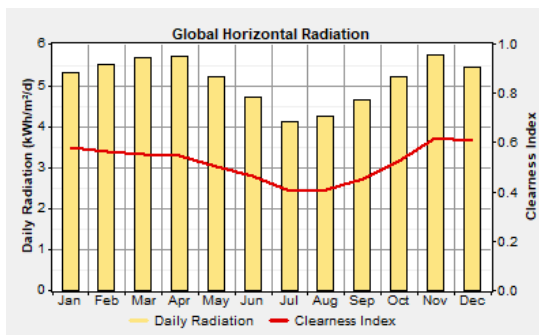

Fig 3.4: Solar radiations for the community.

Model System (Homer)

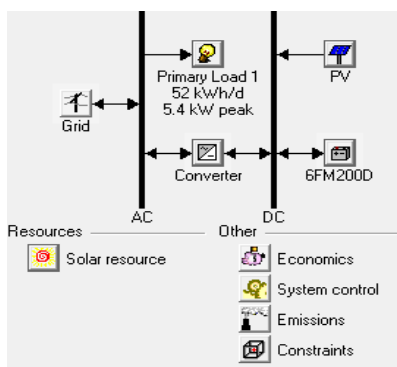

Fig 3.5 Model system

(viii) Evaluation of the System (MATLAB)

The irradiance (the rate at which the sunshine), it is connected to the filter to give us the exact irradiance of the solar panel. Since the temperature varies, the values were set at different temperature as follows; 40°,45°,35° and 45° respectively. The temperature also has a filter to give us the exact temperature of the PV arrays. A DC/DC booster is connected to the PV arrays in order to give us the energy generated from PV arrays. The boosters were connected together on a bus (wire) then connected to an inverter to and also connected to an inductive resistor. A 94kVA load is connected to test the power generated. From the inductive resistor, it was connected to a 260v/26kVA transformer, so from the transformer to a converter then to a battery, so from the transformer to the distribution grid for proper usage.

4. Result and Discussion

Result

At the end of the design, the output of the project should be able to augment for at least 18 hours

electricity supply in the case study area (Ilesha garage, Akure, Ondo state), with the help of HOMER in optimizing for the best option of Hybrid Renewable Energy System. Figure 4.1 shows the equipment to be considered for the system and the cost and replacement of the equipment for 25 years. It also explained the connections between the equipment and their working principle.

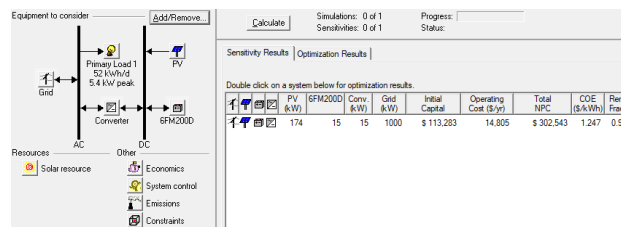

Fig 4.1 Optimization result

Figure 4.2 shows the cost summary of equipment for the system optimized by the HOMER for the study for 25 years.

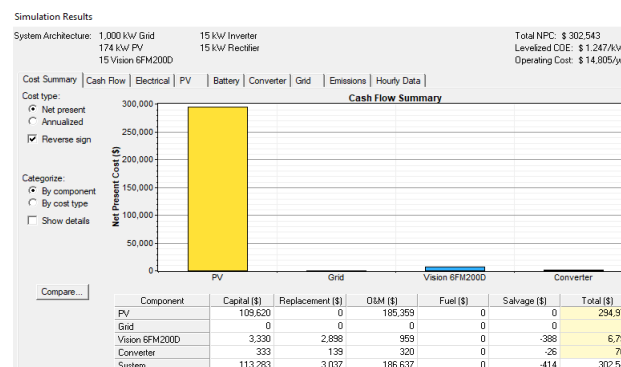

Fig.4.2 Cost summary of the system.

Figure 4.3 shows the cash flow of the equipment for the system for 25 years optimized by the HOMER

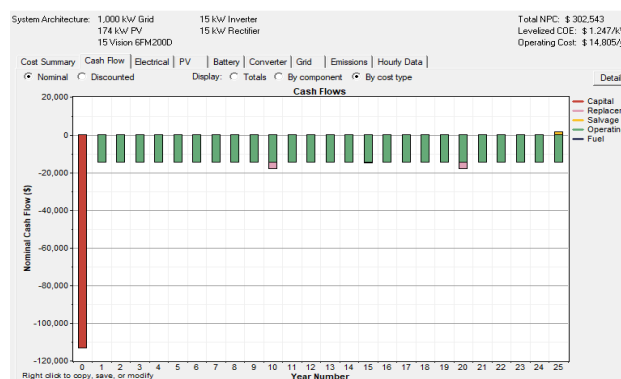

Fig. 4.3 Cash flow of the system

Figure 4.4 shows the monthly average electricity production of equipment for the system optimized from HOMER.

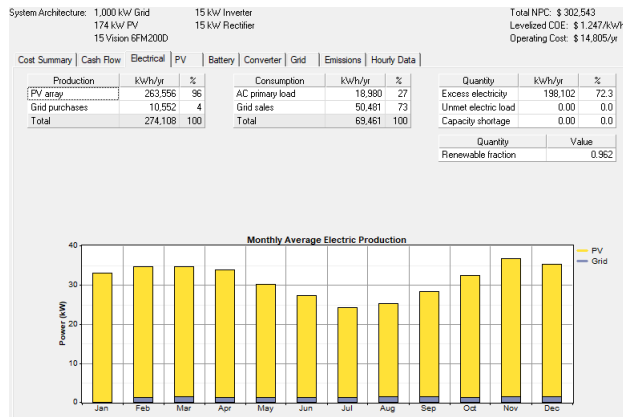

Fig.4.4: Monthly average electricity production.

Figure 4.5 shows the photovoltaic (PV) output of the system optimized from the HOMER.

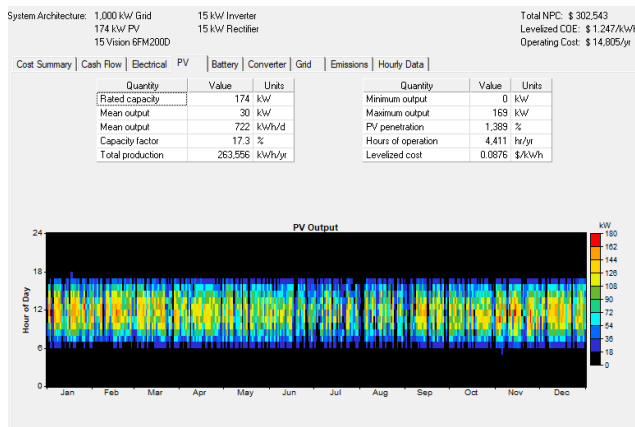

Fig. 4.5 PV output

Figure 4.6 shows the working principle and the output of the converter which work as an inverter and also a rectifier optimized by the HOMER.

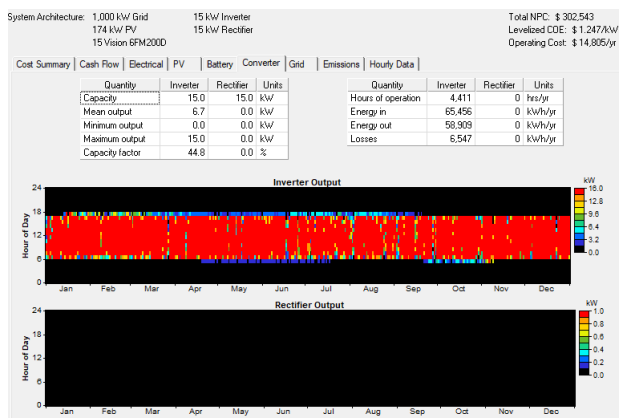

Fig. 4.6 Inverter output

Figure 4.7 shows the working principle and the output of the battery for the system optimized by the HOMER.

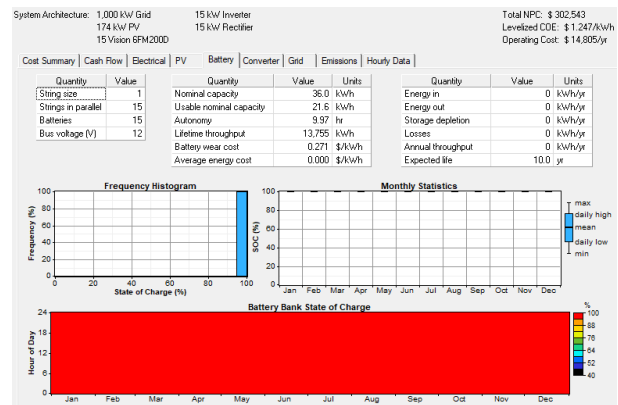

Fig. 4.7 Battery bank state of charge

Cost of Components Used In the System

Table 4.2 Cost of components used in the system

Equipment	Quantity	Capital (N)	Replacement (N)	O&M (N)	TOTAL
Pv panel	174	39,463,200	-	66,729,240	106,192,440
Battery	15	11,988,000	10,432,800	3,452,400	25,873,200
Inverter	15	11,988,000	5,000,400	115,200	285,120
Charge controller	15	46,440	46,440	-	743,040
Cable	-	2,800,000	2,800,000	-	5,600,000
Land	2 PLOTS	2,000,000	2,000,000	-	4,000,000
Workmanship	-	4,000,000	4,000,000	-	8,000,000
Miscellaneous	-	2,500,000	-	-	2,500,000
Grand total					129,907,920

Cost of Distribution from Bedc

In Ondo State Nigeria, the electrical distribution company charges residential at N31.26 per kilowatt for one hour (kWh). The kilowatt supplied to this community is 52.272kW.

$N31.26 \times 52.272 \text{ kW/h} = N1634.02272$ (hourly).
 $N1634.02272 \times 24 = N39216.54528$ (daily).
 $N39216.54528 \times 30 = N1176496.3584$ (monthly).
 $N1176496.3584 \times 12 = N14117956.301$ (yearly)
 $N14117956.301 \times 25 = N352,948,907.52$ (for 25 years).

This calculation shows the cost of electricity supply to this community (Ilesha garage, Akure) for 25 years at the rate of N31.26 per hour.

Simulation Results from MATLAB

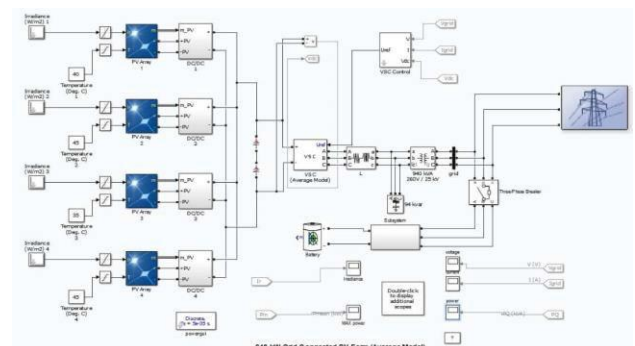

Fig.4.8: 940 kW Grid connected PV farm

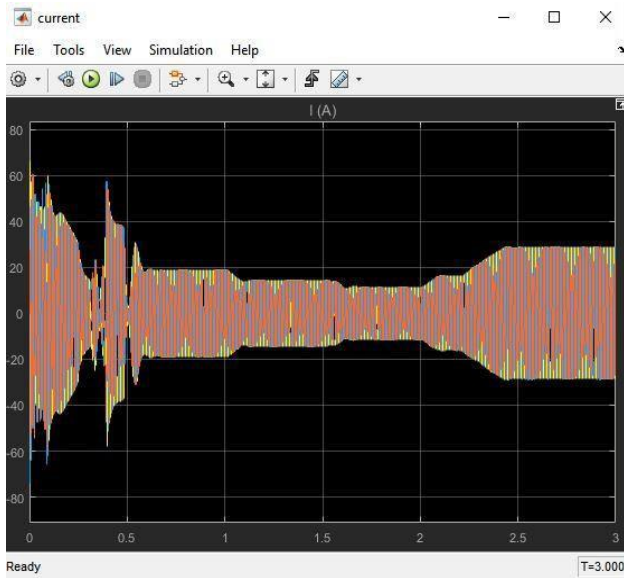

Fig. 4.9: Current output

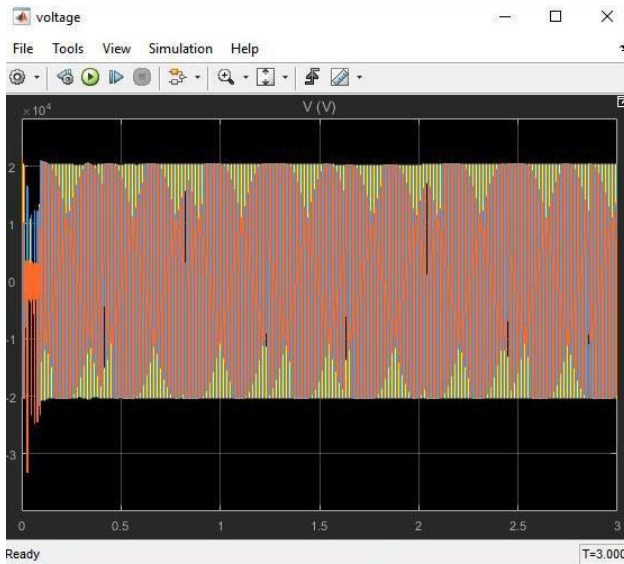

Fig.4.10: Voltage output

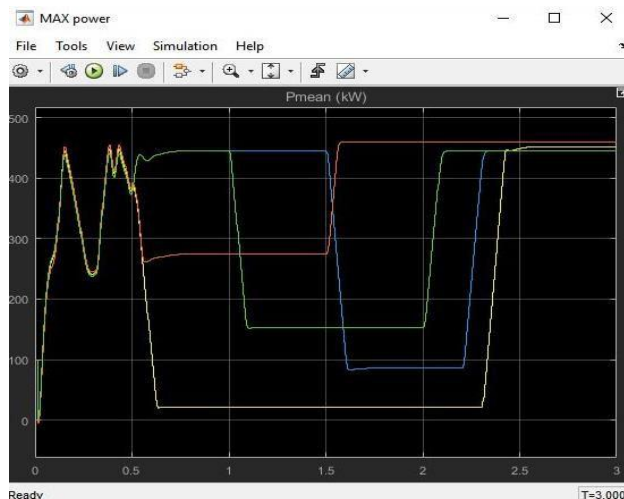
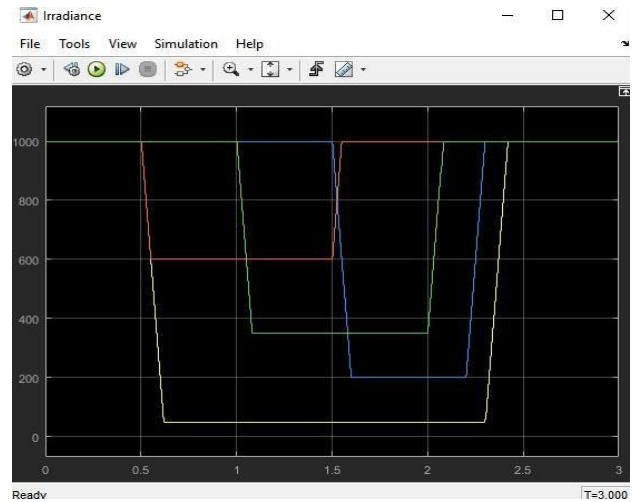

Fig.4.11: Maximum power output



Conclusion and Recommendation

Conclusion

Recent approaches when solving the problem of electrification requirements for isolated consumers rely on wind power and photovoltaic driven standalone hybrid power systems. The research presented in this research, is a typical case-study of determining the appropriate energy power system for remote area object. Configuration of the power system depends on the electrical load and the location of the object.

Based upon average (peak) load power system is dimensioned, while micro-location of the object determines availability of renewable resources. Since connecting the isolated object to conventional grid is too expensive, the only alternative is to design hybrid SAPS, which is designed with HOMER computer model. HOMER combines both economical and electrical aspects while searching for the optimal power system configuration. Since results of the power system simulation with HOMER software are highly dependable on the input data, a special attention was brought upon collecting the accurate technical sheets, while component prices are taken from the market. Although HOMER stands for reliable software, it has its limitations. When electrical load is not constant through the year, HOMER will badly calculate and present peak load, autonomy of battery bank and expected battery life. Also, HOMER does not consider losses on the AC bus, and it optimises the operation of the fossil fuel generator. However, those limitations do not have any impact on the results of the simulation in this research, since power system has relatively small rated power. When comparing optimal power system results, solar PV is cost effective only if power system is used for 9 or 12 months. Cost of energy (COE) in those configurations is approximately 0.45 \$/kWh, which leads to conclusion that such configurations would be cost effective even if they were grid-tries. Due to the fluctuating nature of the renewable energy resources, and regardless of the input data accuracy, computer models can perform feasibility analysis, while the

actual performance of hybrid power systems cannot be accurately predicted. In conclusive, the development of an alternative hybrid power system using HOMER is cost effective, reliable to generate power on a long run.

Recommendation

The research can be expanded further by designing a suitable renewable energy equipment that can be correctly better in terms of the terrain and cost effectiveness which can augment for 24 hours power outage in this community (Ilesha garage, Akure). The project can be implemented by the residents in this community so enjoy steady and stable power supply which is economical which can as well give Benin Electricity Distribution Company Plc. (BEDC) an opportunity to distribute utility to other communities and increase hourly supply so as to improve the standard of living economically. Also we cannot but appreciate Mr. Adepoju Gbemileke Temitope the Technician that carried out the fabrication of this Hybrid Power System.

References

- American Wind Energy Association (2008). AWEA Third Quarter 2008 Market Report. Retrieved March 20, 2009, from AWEA: <http://www.awea.org/publications/reports/3Q08.pdf>
- American Wind Energy Association. (2007). Wind Energy Today. Retrieved March 16, 2009, from Wind Energy Today: <http://www.awea.org/pubs/factsheets/Wind Power Today Final.pdf>
- Ayres, I., & Nalebuff, B. (2006) Easy Savings. *Forbes*, pp. 146-146, September 4.
- Bernal-Agustin, J. L., & Dufo-Lopez, R. (2009). Simulation and optimization of stand-alone hybrid renewable energy systems. *Renewable and Sustainable Energy Reviews*, 8.
- Chan, W. W. (2005). Predicting and saving the consumption of electricity in sub-tropical hotels. *International Journal of Contemporary Hospitality Management*, 17, 228-238.
- Dalton, G., Lockington, D., & Baldock, T. (2009). Case study feasibility analysis of renewable energy supply options for small to medium-sized tourist accommodations. *Renewable Energy*, 34, 1134-1144.
- Dalton, G., Lockington, D., & Baldock, T. (2009). Feasibility analysis of renewable energy supply options for a grid-connected large hotel. *Renewable Energy*, 34, 955-964.
- Dalton, G., Lockington, D., & Baldock, T. (2008). Feasibility analysis of stand-alone renewable energy supply options for a large hotel. *Renewable Energy*, 33, 1475-1490.
- Ellis, M. W., Von Spakovsky, M. R., & Nelson, D. (2001). Fuel Cell Systems: Efficient, Flexible Energy Conversion for the 21st Century. *IEEE*, 89, 1808-1818.
- Environment Canada. (2008). Wind Rose, Wind Speed Histogram, and Turbine Formula. Retrieved April 1, 2009, from Canadian Wind Energy Atlas: <http://www.windatlas.ca/en/rose.php?field=EU&height=30&season=ANU&no=55&ni=216&nj=360>
- Farooque, M., & Maru, H. C. (2001). Fuel Cells - The Clean and Efficient Power Generators. *IEEE* 89, 1819-1829.
- Guizzo, E. (2008, March). *IEEE Spectrum*. Retrieved March 16, 2009, from *IEEE Spectrum*: www.spectrum.ieee.org/mar08/6020
- Mateus, T., & Oliveira, A. C. (2009). Energy and economic analysis of an integrated solar absorption cooling and heating system in different building types and climates. *Applied Energy*, 86, 949-957.
- Siracusa, G., La Rosa, A. D., Palma, P., & La Mola, E. (2008). New frontiers for sustainability: emery evaluation of an eco-village. *Environ Dev Sustain*, 10, 845-855.
- Solar Energy industries Association. (2008). 2008 Year in Review. Retrieved March 19, 2009, from seia: http://www.seia.org/galleries/pdf/2008_Year_in_Review_small.pdf
- Nalluri, S. K., & Parasaram, V. K. B. (2015). Automating Software Builds with Jenkins: Design Patterns and Failure Handling. *International Journal of Technology, Management and Humanities*, 1(01), 16-33. <https://doi.org/10.21590/ijtmh.01.02.03>
- Solar Energy Industries Association. (2008). About Solar Energy. Retrieved March 20, 2009, from SEIA: http://www.seia.org/cs/about_solar_energy
- Swisher, R., Real De Azua, C., & Clendenin, J. (2001). Strong Winds on the Horizon: Wind Power Comes of Age. *IEEE*, 89, 1757-1764.
- U.S. Department of Energy. (2009). NREL: Solar Research Home Page. Retrieved April 1, 2009, from National Renewable Energy Laboratory Home Page: <http://www.nrel.gov/solar/>
- Woody, T. (2008, October 27). The Future of Wind Power. *Fortune*, pp. 59-60.