

Research Article

Dynamic Voltage Restorer for Voltage Sag Mitigation

Muhammad Sufiyan¹, Bilal Ahmad¹ and Ali Kumail*¹

¹School of Electrical Engineering, Sarhad University, Pakistan

*¹School of Physics and Electronic Engineering, Hainan Normal University, China

Received 21 Aug 2022, Accepted 01 Sept 2022, Available online 10 Sept 2022, Vol.10, No.3 (Sept 2022)

Abstract

Electrical power plays a key role in the modern world. With growing technological inventions and our reliability on the electrical energy, it is now considered as the inevitable need. From complex industrial machinery to data centers around the globe, the economies are thriving on electrical power. Although there has been a lot of development on issues related to delivering the power to the end consumers, the critical question i.e. the quality of power still has many areas of concern which are needed to be addressed. With the introduction of a myriad of high-end tech equipment, sophisticated computers, and electronic devices, the power quality can easily jeopardize the functionality and reliability and can put this equipment at risk which can cause a considerable loss in terms of both financial and economic aspects. This paper discusses the power quality improvement by introducing the Dynamic Voltage Restorers on the distribution end of the power system. DVRs can produce active and reactive power. With properly controlled mechanisms, this generated power can be injected into the system to overcome the disturbances and ensure the quality of the power supply. The DVRs addresses the two major areas of power quality. Voltage sag and the voltage swell. The selection of DVRs is primarily based on easy-to-implement and cost-effective solutions as compared to the other industrial solutions. The paper will analyze the effect of the DVRs on the power quality by using a prototype DVR model based on a 1kVA load connected to a simulated distribution feeder. DR program for energy management.

Keywords: Power Quality, Voltage Sag, Dynamic Voltage Restorers.

1. Introduction

Electrical power is an important element of today's living structure. With the ever-growing population, the power system has become more complex than ever to meet the needs of people. And with it, comes the matter of power quality which has become the concern for Utility companies, engineers, consumers, and other stakeholders [1]. Power Quality defines the characteristics of voltage and its parameters i.e. magnitude, frequency, and waveform from generation to the distribution to the end consumers. All the electrical and electronic equipment are manufactured to be operated at a defined voltage and frequency [2]. The power system is designed to distribute the power at these defined parameters. The load on the consumer end comprise of both linear and non-linear load. These non-linear loads include variable speed drive, electronic devices, uninterruptible power supplies, and the static power converters which are considered as the biggest form of non-linear loads.

Power quality encompasses a wide range of disturbances which include voltage rise, voltage drop, voltage sag, swell, harmonic distortion, and voltage flickers [2,10]. Voltage drop mainly occurs during the event of heavy loading of transmission lines and in the event of faults. Voltage rise is the increase in voltage in the receiving end due to the heavy fault currents or in the event when a large load suddenly disconnects from the system. Voltage sag, swell, harmonics distortion and flickers occur due to the presence of non-linear loads [6].

Various techniques have been developed to cope with power quality problems. These include introducing the shunt capacitors, static switches, and energy storage systems [7]. Dynamic Voltage Restorers is the application of energy storage systems that can supply the active and reactive power stored in the batteries to deal with voltage sag, swell, and distortion problems [8]. This paper focuses on DVRs to solve the power quality problems.

The objective of this paper is to explore the energy storage systems and develop a better model of dynamic voltage restorers which would not only ensure a better quality of power but would also be cost-effective enough to integrate into the system on a large scale.

*Corresponding author's ORCID ID: 0000-0002-7853-4462
DOI: <https://doi.org/10.14741/ijaie/v.10.3.1>

2. Power quality improvement techniques

Power quality issues are of major concern today due to the widespread use of electrical equipment and the digitization of services throughout the world. With the increasing number of loads, the nature of power generation, transmission, distribution is being altered to manage the power demand meanwhile not losing the quality of power supply [10]. Scientists, researchers, engineers, and governing bodies of power management have been developing and proposing solutions to the power-related problem through the advent of time [11]. Power quality issues have been discussed in detail considering every aspect of the power domain. IEEE has introduced the basics of power quality in [12] which sets the minimum standards power needs to meet from generation up to the consumer end. Limits for the harmonics and their measurements have been set in [13] which disrupts the standard voltage and current profile. [14] provides the guideline on voltage flickers and their associated standards. IEEE P1250 addresses all the issues related to the voltage fluctuations, surges, types, and levels of faults, and their effect on the equipment [15]. Power quality monitoring can be carried out as per [16]. The standard also defines the terminologies related to power quality. The general measures for the improvement of power quality and about the protection of sensitive consumer equipment have been set out in [17]. IEC defines the parameters of voltage sags, swells, voltage fluctuation, and causes of unbalanced supply in [18]. The standards also provide improved techniques for power quality.

Power quality improvement techniques are being developed since the advent of electric power as a consumer good. The development started with the passive filters being used as the compensation device. Due to their significance they were improved with the time. In the second phase, active power filters were introduced which combined the semiconductor switches and energy storage devices. Passive filters had several limitations which posed several challenges. The development of active power filters bridged this gap and a significant improvement was made in the current and voltage compensation. In the third phase, hybrid filters were introduced. Hybrid filters included the transistors such as MOSFETs which gave them the advantage of fast and accurate switching. After the hybrid filters, custom power devices were brought to the mainstream power market. Custom power devices include the Unified Power Quality Conditioners and FACTS devices. UPQC integrated the shunt and active power filters with a DC link bus. These devices work on both current and voltage schemes with shunt and series inverter, respectively. They not only offer the current and voltage compensation but also provided compensation against currents produced by the non-linear loads. FACTS devices are the advanced category of custom power devices with real-time control mechanisms for the inverter switching to

provide precise compensation. Custom power devices encompass a wide range of devices including DSTATCOM, DVRs, and UPQCs. Static Var compensators, distribution static compensators dynamic voltage restorers are most widely used among these FACTS devices. [28] have proposed various configurations and compensation techniques which can be employed with these FACTS device to achieve better compensation.

3. Dynamic voltage restorers

Dynamic Voltage Restorer is a form of custom power device which is used for the mitigation of voltage sags on the distribution side. DVRs are considered as one of the most efficient and cost-effective solutions to voltage sags. DVR is also called Series Compensating Device (SCD) or a static series compensator (SSC). It was first introduced in North America in 1996 on a 12.47 kV distribution system [22]. DVR maintains the supply voltage at the nominal magnitude and respective phase by injecting the voltages into the system. These are placed on the distribution feeders at the point of common coupling as seen in the figure.

Features

DVR has been recognized as one of the widely used custom power devices because of various features. Some of the features have been listed below.

- Cost-effective
- Easy to design
- Small size
- Fast response to the voltage disturbance
- Ability to manage the active power flow
- Requires less maintenance

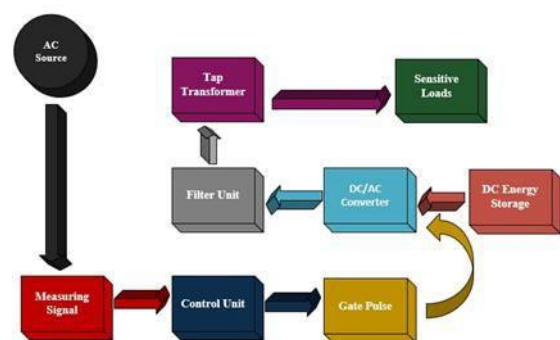

Basic design

The basic design of DVR consists of the following components.

- Voltage source inverter (VSI)
- Energy Storage Device
- Injection Transformers
- Switches
- Harmonic Filters

- DC Charging Circuit
- Control and Protection Circuit

Operating modes of DVR

There are three basic modes of operation in DVR. Namely, protection mode, standby mode, and injection mode. These modes have been discussed in detail below.

Protection Mode: The protection mode in DVR is designed to protect the DVR in the events of fault such as a short circuit. During the short circuit, the current on the distribution feeder will exceed the tolerable value and can damage the DVR. For the protection of DVR, a bypass switch is used to protect the device from fault currents. In such an event, the switch isolates the DVR from the system by providing another path to the fault current.

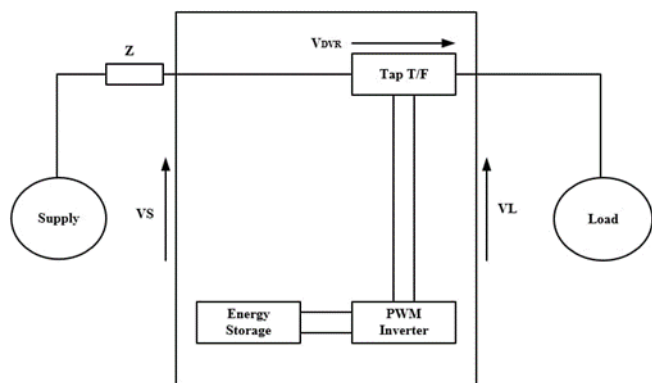

Figure1: General Arrangement of DVR

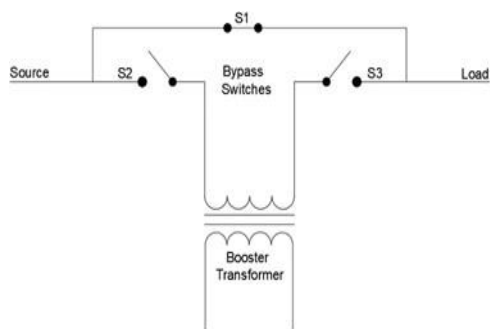

Figure3: DVR Protection Mode

Standby Mode: Standby mode is the idle mode of DVR. This mode is applied by shorting the LV winding of the injection transformer at the converter side. Due to this, there is no switching of IGBTs and DVR remains in the standby mode. The load current completely passes through the HV winding of the transformer.

Injection Mode: Injection mode also called the booster mode is the normal operating mode of DVR when it injects the voltages required for the compensation whenever there is a disturbance in the

system. DVR starts operating in the injection mode as soon as it detects the voltage sag. The process is followed by the injection of 3 phase sinusoidal voltages through the booster transformer into the system to mitigate the voltage sag.

DVR compensation techniques

Voltage compensation of a DVR primarily depends on the nature of voltage sag. DVR control scheme allows us to generate the compensation voltage as per voltage disturbance which appears on the distribution line. The compensation techniques vary due to several other factors which include the power rating of a DVR, nature of the load, and type of voltage sag. A high rated DVR can compensate for severe voltage sags without any lag in a short period. Whereas a DVR with a small rating is useful for small voltage sags. DVR is designed keeping in view the system requirement and nature of full current which flows into the system. Four common techniques of DVR voltage injection have been discussed below [20].

Pre-Sag Compensation: In Pre-sag compensation method, DVR continuously monitors the system voltage through the feedback control system. When there is a voltage dip due to the fault conditions, the control system would detect the dip and DVR will proceed to inject the difference voltage in the system to restore it to the normal nominal supply voltage [19]. The voltage is injected at the point of common coupling. Whether it is a difference between the magnitude or a phase angle, DVR is responsible to compensate both the nature of disturbance to restore the power quality for the sensitive loads. Power injected by the DVR in this mode cannot be altered and is defined by the load condition and nature of fault occurring on the distribution system.

$$VDVR = V_{pre-sag} - V_{sag}$$

In-Phase Compensation: During this compensation, the injected voltage is in phase with the supply voltage. This compensation method does not consider the phase angles of the load voltage and pre - sag voltage. It also neglects the load current and restores the voltage sag by injecting the compensating voltage of a required magnitude to restore the power quality. When there is a voltage sag in the supply voltage, the DVR will just inject the missing component based on voltage sag magnitude required to restore it to the normal supply voltage. In - phase compensation method is rather a direct method of compensation and is usually applied for the non-sensitive loads. Since it neglects the phase angles of voltages, it is not considered desirable for sensitive loads.

$$V_{Load} = V_{Pre-sag} \quad 2) \quad V_{Load} = V_{sag} + V_{DVR}$$

In-Phase Advanced Compensation: This mode of compensation makes use of reactive to achieve compensation. In this method, the angle between the

load current and voltage sag is minimized. Therefore, the real power spends by the DVR reduces. By making the voltage phasor in perpendicular with the load current, the component of active power becomes zero. Thus, saving the energy stored in the batteries. The limitation factor in this compensation technique is the load current and voltage which are fixed. Therefore, only the phase of voltage sag can be varied. This mode only utilizes the reactive power that is why it cannot be applied to mitigate all kinds of voltage sags and thus is very much limited to the application. However, this technique can be suitable for the systems where the use of real power is a major concern and required voltage sag mitigation can easily be achieved through reactive power compensation.

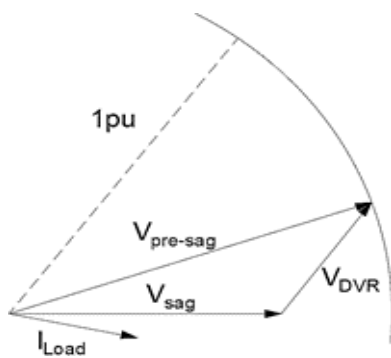

Figure 5: Single Vector Diagram of Pre-sag Compensation

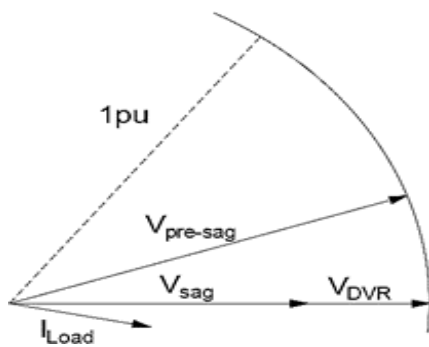

Figure 5: Single Vector Diagram of In-Phase Compensation

Hybrid Compensation Method: Hybrid compensation method is a combination of Pre-sag and In-phase compensation method. This method makes use of the advantages of both techniques without jeopardizing the voltage sag compensation [21]. This method finds many applications since it does not need dc link capacitors and modulation techniques which makes the compensation less costly and simple to operate. Another type of hybrid compensation method is the combination of pre sag compensation and in phase advanced compensation in which the voltage sag is first mitigated by the pre sag compensation method and later on in-phase advanced compensation method takes over to minimize the use active power while

keeping the voltage profile balanced [22]. Hybrid compensation methods make the best use of in-phase compensation methods since they are not very applicable alone. But combined with other techniques, they save the economy and enhance the overall functionality of DVRs.

DVR control strategies

The purpose of a control system in a DVR is to maintain the constant magnitude of voltage required for the sensitive load. Without an effective control system, the DVR cannot perform its functions. The following are the functions of the control system in DVR.

- Detect the voltage sag when it occurs in the system due to the fault.
- Generate the reference voltage required for the mitigation.
- Control the inverter
- Protect the system in all conditions

The detection of a voltage sag depends on the detection algorithm, the control system operates on. The control system must have an accurate detection scheme which will ensure the performance of the control system. There is a multitude of detection techniques that are employed in the control system, some of which have been tabulated below.

Techniques Description

RMS Method Root Mean Square is the simplest method of sag detection. It requires less memory to calculate the sag. The first point when VRMS starts to drop below 0.9 is considered as the starting point of sag and is calculated for half a cycle. The drawback of the RMS method is that it cannot differentiate between the harmonics and a fundamental frequency.

Peak Value Method The peak value method compares the peak of supply voltage with the reference voltage. The difference value between the two is considered as the sag. The controller can be adjusted to a value that is in the percentage. Upon this difference, the controller will activate the inverter for the sag compensation

Discrete Fourier Transform Method This method uses the Fourier transform exponential functions to find the magnitude and phase angle of the voltage waveform. FT method can calculate the harmonics along with the voltage sag. The drawback of this method is that it requires a lot of computation and full one cycle to return the information which causes the delay.

Windowed Fast Fourier Transform Method WFFT is another application of the Fourier transform. And is preferred because of its real-time application. It can

detect the voltage sags along with the harmonics. It requires a full one cycle to return the computation.

Period Phase Method This method also compares the RMS value of phase voltage. It monitors the start and the end of sag to obtain the definite value. The response time of this method is better than Fourier Transform methods.

Numerical Matrix Method NM method computes the phasor voltages for each phase through a numerical matrix scheme. The voltage difference in an event of sag is calculated and becomes readily available for the compensation.

There are two major categories of controllers on DVR. Linear controllers and non-linear controllers. Since DVRs are mostly employed for the non-linear loads therefore non-linear controllers are more pervasive. However, linear controllers also find their application in a variety of domains depending on the requirement. The following chapter discusses these categories in detail.

Linear Controllers

There are three main types of the linear controller which have been developed up to date.

Feed-Forward Controller

The feed-forward controller works on the principle of the open-loop control function. The method injects the difference of voltage between the sag voltage and pre-sag voltage. There is no detection of load voltage in this controller. The monitor monitors only the supply voltage and relates it with the reference voltage. The difference between the two values is the injection voltage which inverter supplies to the system. The feed-forward controller has the disadvantage of steady-state error.

FeedbackController

The feedback controller works on the closed-loop function. The load voltage is constantly monitored and compared to the reference voltage. If there is a difference between the two the inverter generates the voltage signal based on that difference and feeds it to the distribution line. The DVRs keep injecting the voltage signals until the load voltage becomes equal to the reference voltage. The feedback controller has a very accurate response to the voltage sags in the system. However, the recurrent feed-back process results in the time delay.

CompositeController

The composite controller uses both feed-forward and feedback control strategies. The feed-forward control scheme is used on the supply voltage. The feedback control scheme is used for the load voltage. Being the hybrid controller, the composite controller offers the benefits of both control schemes with better

compensation as compared to each scheme used alone. However, this adds to the complexity of the controller along with the time delay of the feedback controller.

Non-Linear Controller

DVR itself is a non-linear device since it employs the semiconductor switches. Although the linear control schemes work efficiently; under high unstable conditions, the linear controller does not function well. Therefore, non-linear control schemes have been introduced to cope with this issue.

Artificial Neural Network Controllers

The artificial Neural Network control method is a complex control system that can learn from the system behavior and provides improved compensation strategies through the method of interpolation. These controllers are adaptive and develop their schemes over time. ANN controllers are very complex and expensive to design. With the evolution of artificial intelligence, these controllers may find their application in the extensive future smart grid.

Fuzzy Logic Controllers

Fuzzy logic controllers can compute long complex mathematical equations with accuracy. Where there is a need to perform complicated and large mathematical functions, fuzzy logic controllers are best to do the job. With these controllers, errors can easily be tracked. However, as with the Artificial Neural Network controllers, these controllers are difficult to design and implement and require fast computing.

Space Vector Pulse Width Modulation Controllers

These controllers utilize space vector methodology on the inverter voltage to regulate the inverter operation. SPVM controllers have recently been under a lot of interest for researchers due to their easy implementation and better voltage utilization. Several SVPM control algorithms have been proposed which have been found effective to utilize in the non-linear control domain. As compared to other non-linear control schemes, these controllers may see a lot of development

4. DVR implementation

A small-scale DVR prototype has been prepared to test and implement the voltage sag and swell compensation. The prototype has been configured and successfully tested; the implications of which have been discussed in the next chapter. This chapter discusses the assembly and major components that have been used to develop the prototype.

Hardware configuration

The hardware configuration has been divided into Power Circuit and Control Circuit. The power circuit of the model DVR consists of the following.

- Voltage Injection Transformer
- DC Batteries
- Voltage Source Inverter
- Arduino Uno as the control circuit.

DVR operation

The load is connected on the secondary side of the booster transformer and the primary side of the transformer voltage source inverter is connected. The voltage can be examined using the CTs and PTs which take 220V supply from the line. PT is used to monitor the voltage while CT is used to monitor the current. The potential transformer gives the 5V on the secondary side which is stepped down to 2.5V by using the voltage divider. Now, 5V from Arduino and step it down to 2.5V by the voltage divider. The 2.5V of PT and Arduino is given to Arduino analog pin A0.

For current monitoring 2.5mA, CT, and 1K resistor is used. The 2.5V is taken and combines it to Arduino 2.5V and puts it on the analog A1. When -ve 2.5V of PT and CT combines with Arduino 2.5V analog pin gets 0V and when it gets +ve 2.5V then analog pin gets 5V.

In the control circuit, Arduino Uno is used for voltage monitoring. When the controller senses the voltage less than the rated value, it generates the PWM signal. PWM signal goes to the base of the transistor of the MOSFET driver of the control circuit.

When the base of the transistor of the MOSFET driver receives the signal from the controller, it can send a signal to the gate B1 and B2 of the MOSFET inverter module for each cycle. The width of the PWM signal depends upon the depth of the sag. When the inverter module gets signal it can take energy from the energy source, converts it from DC to AC, and sends it to the transformer which can step it up to the required voltage and inject in the line.

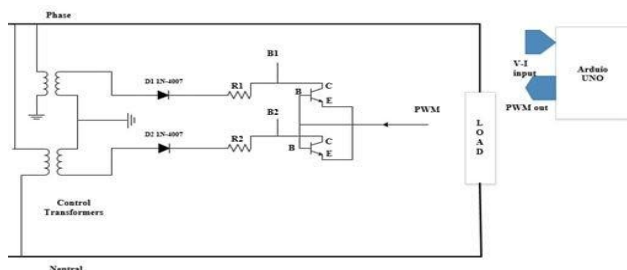

Conclusion

In this project, the DVR is implemented for single-phase loads. This hardware is designed to compensate for the voltage sags and the voltage swells. It is concluded that the linear control is easy to implement and requires fewer computations. DVR offers a cost-

effective and easy-to-implement solution for the voltage sags as compared to the other solutions. The main purpose of using DVR is to protect the sensitive equipment of the costumers and to maximize efficiency in the production of the industries. The project set forth a cost-effective and easy-to-implement technique for the voltage disturbances. Voltage Sags and swells at all levels can be easily compensated via this technique. Furthermore, it can easily reduce the risks against the transients in the system and help stabilize the voltage profile.

References

- [1] S. Bhattacharyya, Myrzik, JAM, Cobben, JFG, Kling, WL & Didden, "Need Of Voltage Quality Regulation In The Future Electricity", 2007
- [2] A Agarwal, S Kumar, S Ali, MIT International Journal of Electrical and Instrumentation Engineering, "A Research Review of Power Quality Problems in Electrical Power System", Vol. 2, No. 2, Aug. 2012, pp. (88-93)
- [3] IEEE Recommended Practice and Requirements for (DVR)". Conference Proceedings 1998., Thirteenth Annual Applied Power Electronics Conference and Exposition, APEC. (Vol. 2, pp. 986-993). IEEE. 1998.
- [4] E. Muljadi and H. E. McKenna, "Power quality issues in a hybrid power system," IEEE Transactions on Industry Applications, vol. 38, pp. 803-809, 2002.
- [5] M. H. Bollen, MHJ, "Understanding Power Quality Problems-Voltage Sags And Interruptions', IEEE Press series on power Engineering, New York, 2001
- [6] A. Jabbar, W. Hussein, S. Saeed. "Power Quality Problems And Improvement Techniques", 330312735, 2019
- [7] S. Khalid and B. Dwivedi, "Power Quality Issues, Problems, Standards & Their Effects In Industry With Corrective Means", International Journal of Advances in Engineering & Technology, vol. 1, pp. 1-11, 2011.
- [8] M. Bongiorno, A. Sannino, & L. Dusonchet, "Cost-Effective Power Quality Improvement For Industrial Plants", Proceedings of IEEE international conference on power technology, Bologna, vol. 4, pp. 1-6. 2003
- [9] E. Muljadi and H. E. McKenna, "Power quality issues in a hybrid power system," IEEE Transactions on Industry Applications, vol. 38, pp. 803-809, 2002.
- [10] R. C. Sennon, An Overview of Power Quality Standards and Guidelines from the End-User's Point-of-View, 2014
- [11] A. Kusko and M. T. Thompson, "Power quality in electrical systems": Publication - McGraw-Hill, 2007.
- [12] IEEE STD 1433 - 2014. Power Quality Definitions. A standard glossary on power quality terms. 16 June 2014
- [13] IEEE STD 519 - 1992 IEEE Recommended Practices and Requirements for Harmonic Control in Electrical Power Systems
- [14] IEEE STAD P1453/D8 - 2011 - IEEE Draft Recommended Practice for the Analysis of Fluctuating Installations on Power Systems
- [15] IEEE P1250/D6 -2017 - IEEE Draft Guide for Identifying and Improving Power Quality in Power Systems.
- [16] IEEE 1159 -2019 - IEEE Recommended Practice for Monitoring Electric Power Quality.
- [17] IEEE - ANSI C62.41 - 1991 - IEEE Recommended Practice for Surge Voltages in Low-Voltage AC Power Circuit.
- [18] O. P. Mahela, A. G. Shaik, "Topological aspects of power quality improvement techniques": A comprehensive overview, Renewable, and Sustainable Energy Reviews, Elsevier, 27 December 2015

- [19] V Cárdenas, M.A. González-García, and R Álvarez-Salas. "A Dynamic Voltage Restorer with the Functions of Voltage Restoration, Regulation Using Reactive Power, and Active Filtering. *Electric Power Components and Systems*", 43(14), 1596–1609. 2005.
- [20] A. Kara, P. Dahler, D. Amhof, and, H. Gruning. "Power supply quality improvement with a dynamic voltage restorer"
- [21] S. Choi, S., Li, B. H., and Vilathgamuwa, D. M.. "Dynamic voltage restoration with minimum energy injection". *IEEE Transactions on power systems*, 15(1), 51–57. 2000
- [22] C. Fitzer, M. Barnes, "Voltage Sag Detection Technique for a Dynamic Voltage Restorer", *IEEE Transactions on Industry Applications*, vol. 40, no. 1, pp.203 January/February 2004.
- [23] Nalluri, S. K., & Parasaram, V. K. B. (2015). Automating Software Builds with Jenkins: Design Patterns and Failure Handling. *International Journal of Technology, Management and Humanities*, 1(01), 16-33. <https://doi.org/10.21590/ijtmh.01.02.03>
- [24] L. Haichun, X. Lizhi, and X. Shaojun. "Anew detection method of voltage sag based on period phase concept". 4th IEEE Conference on Industrial Electronics and Applications, ICIEA. (pp. 3333–3337), 2009 Harmonic Control in Electric Power Systems. IEEE-SA Standards Board. 27 March 2014